



Value • Performance • Quality

72" T-SERIES RESTAURANT RANGE

Restaurant Range Series provides as standard many of the optional upgrades normally offered at a premium on other Range lines. The standard include a stainless steel front, ledge, backguard and shelf, sides. The stainless steel seams and edges are welded so the Range looks as good as it performs.

Standard features include:

- 72" Range includes two 30" ovens with 12 open burners
- Stainless steel front oven doors, landing ledge and backguard with shelf, control panel and kick plate.
- Welded and finished stainless steel seams.
- Porcelainized oven interior includes: sides, rear, deck and door linings.
- Oven burner provides 40,000 BTU/hr. Equipped with one heavy-duty locking chrome plated rack.
- Cool to the touch knobs.



TSR-12

Design Features:

- 12" x 12" heavy duty cast iron section grates remove easily and safely. Cast-in bowl directs heat to the cooking surface.
- Highly polished 1" plate with 3" wide grease trough.
- 20,000 BTU/hr burner for every 12" of griddle surface. Located on the left side of range top.
- Manual controls are standard, thermostatic controls optional.

Options & Accessories

- Additional Racks
- Thermostatic controls for griddles
- Reinforcement channels for mounting cheese melter/salamander
- Stainless steel stub backs
- Casters – Set of 6
- Quick Disconnect and Flexible Gas Hose

Certifications





Value • Performance • Quality

72" T-SERIES RESTAURANT RANGE

PRODUCT SPECIFICATIONS

Construction: 12 gauge construction with welded front frame. Fully insulated with non-sag fiberglass. Porcelainized oven interior includes, deck and door linings.

Clearance: Legs or casters are required. or 2" over-hang is required when curb mounted. Provide 0" clearance from non-combustible surfaces and 4" from back, 10" from sides from combustible surfaces.

Gas Information: Manifold pressure is 5.0"W.C. for natural gas or 10.0" W.C. for propane gas. Manifold size is 3/4" NPT. 3/4" pressure regulator supplied with equipment to be installed at time of connection.

Must specify type of gas and elevation if over 2000 ft. when ordering.

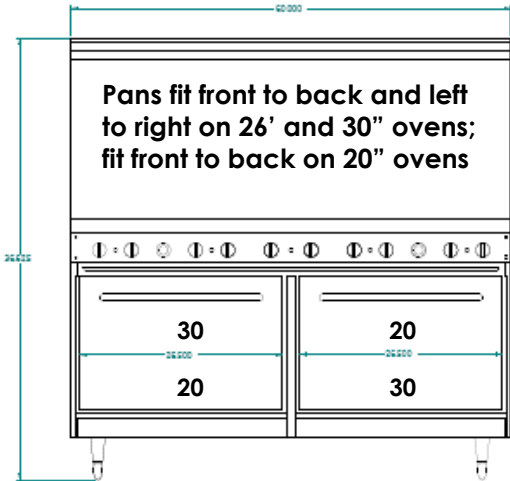

TSR-12

12 burner, two 30" Standard Ovens, 560,000 BTU

TSR-G24-8

8 burner, 24" Griddle, two 30" Standard Ovens, 440,000 BTU

TSR-G36-6

6 burner, 36" Griddle, two 30" Standard Ovens, 380,000 BTU

TSR-G48-4

4 burner, 48" Griddle, two 30" Standard Ovens, 320,000 BTU

TSR-G60-2

2 burner, 60" Griddle, two 30" Standard Ovens, 260,000 BTU

Overall Dimensions:

TSR-12: 33 1/2" D x 56 5/8"H x 72"W

TSR-G24-8: 33 1/2" D x 56 5/8"H x 72"W

TSR-G36-6: 33 1/2" D x 56 5/8"H x 72"W

TSR-G48-4: 33 1/2" D x 56 5/8"H x 72"W

TSR-G60-2: 33 1/2" D x 56 5/8"H x 72"W

Shipping Weight:

TSR-12: 1,150 lbs.

TSR-G24-4: 1,200 lbs.

TSR-G36-6: 1,220 lbs.

TSR-G48-4: 1,165 lbs.

TSR-G60-2: 1,350 lbs.

Freight Class: 85

