

PRODUCT

QUANTITY:

ITEM #

MODELS: RW-1V RW-2V

RW-1V & RW-2V

- RW-1V and RW-2V models have heating elements surrounding the sides that evenly distribute heat throughout the unit.
- Effectively keeps hot foods, soups and sauces at consistent levels above 140 degrees.
- Provided with insulation to protect interior parts and countertops from heat build-up.
- Round Warmers are constructed with heavyduty stainless steel for long life.
- Interior liner is made with durable stainless steel.

Design Features

- 7 quart (RW-1V) and 11 quart (RW-2V) capacity
- Stainless steel housing with stainless steel liner
- Thermostatic control (adjusts to low, medium and high)
- Raised liner edge prevents outside condensation
- Control and cord are located on the back of the warmer
- Electric band element provides fast, even heat
- Wet or dry operation
- Uses standard insets and covers. (Not included)



PRODUCT

QUANTITY:

ITEM #

MODELS: RW-1V RW-2V

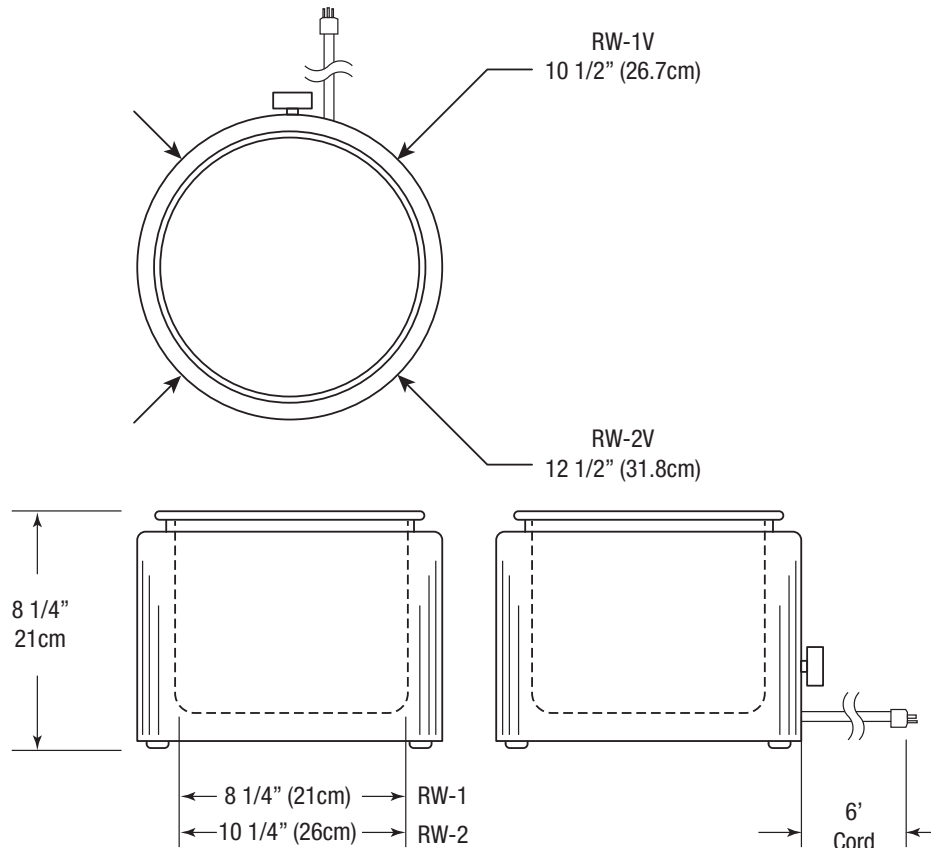

Specifications

Construction

Stainless steel housing; stainless steel liner, fiberglass insulation.

Capacity

RW-1V 7 qts. (6.6L)
RW-2V 11 qts. (10.4L)

Dimensions (H x W x D)

RW-1V 8 1/4" x 10 1/2" Dia
(21cm x 26.7cm)
RW-2V 8 1/2" x 12 1/2" Dia
(21cm x 31.8cm)

Electrical

Each unit is equipped with a 60", three wire grounded power cord which terminates with a standard three pronged male plug. The 120V unit uses a NEMA 5-15P plug.

RW-1V 120V, 500W, 4.2Amps
RW-2V 120V, 700W, 5.8Amps
220V, 700W, 1ph 50/60 HZ
(supplied with out electrical plug)

Shipping

	Standard	Special Pkg.*
RW-1V:	10 lbs. (4.5kg)	11 lbs. (5 kg)
RW-2V	11 lbs. (5 kg)	12 lbs. (5.4 kg)

* Special package includes inset, hinged cover and ladle.

F.O.B. Arizona 85621